

Easypack Cassette®



www.easypack.net

Large air pillows on demand

The Easypack Cassette system generates large tubular pillows having any length and volume, with softness controlled by the packer as each bag is formed. The result is exactly the right amount of fill, every time, with no wastage.

Bags are produced on demand and this eliminates storage and distribution associated with large numbers of small bags.

Large bags mean less material is used, resulting in lower costs and easier disposal when they have done their job.

The Cassette system is suitable for businesses of all sizes whether dispatching just a few boxes or hundreds every day.



Easy-to-use Cassette - manual version



Bags more void fill

Bulky airbags are produced which are individually generated to exactly the right size to fill the space in the box.

Operation is simple - each bag is automatically inflated by the inbuilt fan and is sealed and perforated ready to tear off at the press of a button.

The minimum amount of material is used, meaning lighter weight and less impact on the environment. High quality welds prevent leakage and eliminate air loss in transit.

Both the Easypack Cassette and Cassette SA are supplied on low cost monthly rental.



Choice of systems

The Cassette SA is offered as an alternative to the manual system providing faster production of large airbags.

Simple controls are used to select bag length and number of bags to be produced from 5 up to 20.



Semi automatic Cassette SA keeps up with production

Eco friendly option

A 100% biodegradable and compostable material conforming with EN 13432 is available as an alternative to LD-PE. Biodegradable film has been produced to meet the high standards demanded right now by many customers and will become even more important in helping to preserve the environment in the future.

Economical

Wastage is eliminated as every bag is guaranteed to fill with air, right to the very end of the film.

The large volume bags are a very efficient way of filling voids and protecting your products.



COMPOSTABLE
EN 13432



Film is supplied on quick change "cassettes"



One large bag is often better than many small ones

TECHNICAL DATA

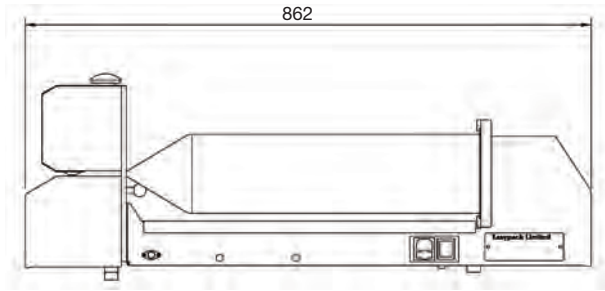
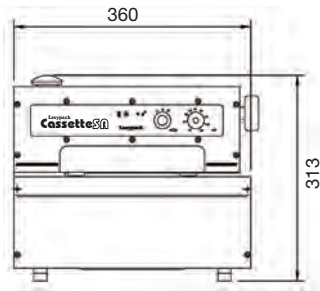

Cassette SA - Semi automatic

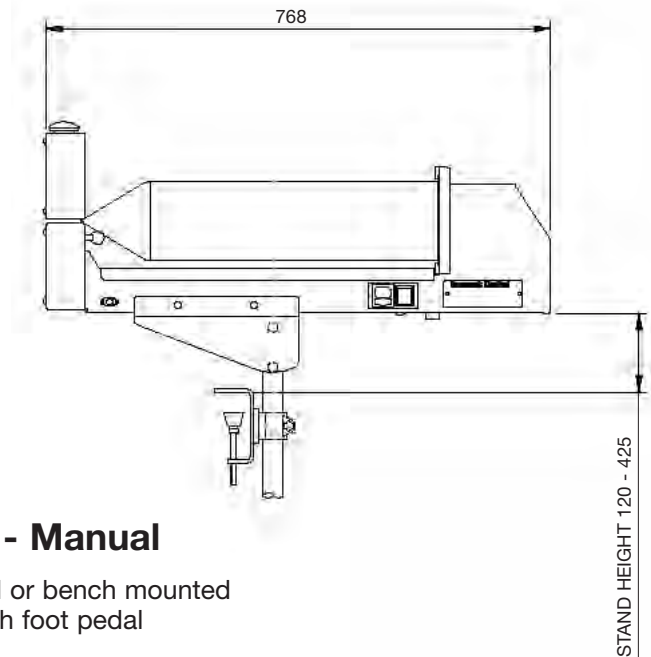
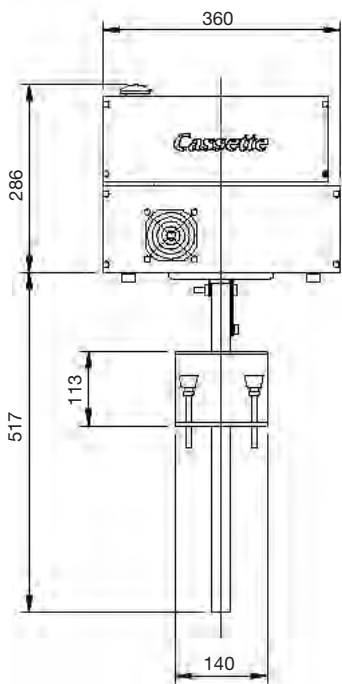

Cassette - Manual

Available with stand or bench mounted
Supplied with foot pedal

ALL MEASUREMENTS IN MM UNLESS OTHERWISE STATED

SPECIFICATION

Machine

Box Quantity
Machine Weight
Output Volume (per cassette)
Film Width (approx.)
Average Output Speed
Pillow Length (variable)
Voltage
Max Power Input

Cassette SA

9 cassettes
27 Kg
up to 0.8 m³
200 mm
11.3 m per min
150 - 1500 mm
220V / 240V
8A

Cassette

9 cassettes
19 Kg
up to 0.8 m³
200 mm
1 bag per 3 secs
150 - 5000 mm
220V / 240V
6.3A



Each cassette produces up to 0.8 cubic metres of air pillows
A box of nine cassettes expands to over 55 times its volume

E&OE